



OSTIM INDUSTRIAL INVESTMENT & BUSINESS INC.

ostim
yatirim



Design and Construction of
Slaughterhouse Systems

INDEX

CATTLE, SHEEP WAITING PLACE	3
CATTLE SLAUGHTERING LINE	3
<i>Slaughtering Cell and Walking Road</i>	3
<i>Cattle Processing Line</i>	4
<i>Cattle Hide Pulling</i>	4
<i>Electronic Scale</i>	4
COLD ROOM RAIL SYSTEM	5
RENDERING	5
SAWS	6
WINGED ANIMALS EQUIPMENT	6
<i>Feeding Pan for Breeders</i>	6
FROZEN MEAT BREAK-UP MACHINE	7
AUTOMATIC CLIPS MACHINE	8
CUTTER 100 LITRES	9
AUTOMATIC FILLING MACHINE	10
COOKING DRYING SMOKING OVEN	11
TECHNICAL DRAWING SAMPLES	12

CATTLE, SHEEP WAITING PLACE



These are the places for piling up the animals, to be slaughtered, with a certain system and preparing them for the slaughtering flow.

The sizes of the Padogs are adjusted as per the slaughtering capacity. The door systems of these room s, made of steel profiles, are made by means of a special system.

This way, the animals are directed to desired place: with a certain order and queue.

CATTLE SLAUGHTERING LINE *Slaughtering Cell and Walking Road*



Cattle Processing Line



Cattle Hide Pulling



This performs 80% skinning process of 1 head cattle.

It has three types: as follows:

- 60 heads per hour
- 40 heads per hour
- 20 heads per hour

Electronic Scale



COLD ROOM RAIL SYSTEM



RENDERING



All of the slaughtering house wastes (blood, hair, bone, etc.) are processed here to a powder form. These powdered wastes are used in animal breeding and they are very nutritious.

SAWS



Cattle Splitter



Hydraulic Hock Cutter



Multi - Purpose Saw



Cattle Hide Pulling

WINGED ANIMALS EQUIPMENT

Feeding Pan For Breeders



Tanks to the separated feeding systems for male and female breeding herd, male breeding herd are not let eat from the feeding pan of female herd.

FROZEN MEAT BREAK-UP MACHINE



Capacity Kg/H	2600						
Engine Power Kw	23,5						
Net Weight Kg	1900						
Dimensions (mm)	A	B	C	D	E	F	G
	2076	1189	887	1118	2496	2031	×

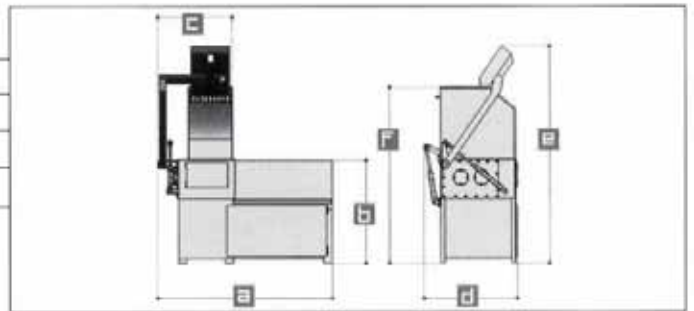

Technical Specification

Used in sausage, spiced sausage, salami, doner kebab and meat bali production and in the meat processing sector with the particular purpose of breaking up shocked meat at .. 40 Co the size of 500 x 500 x 300 to parts in the size of 50 x 50 x 30 mm.

- Equipped with a powerful engine and gearbox system.
- With hydraulic lift.
- With safety switch.
- Entirely made up of 304 quality stainless metal.
- Hygienic.
- Extremely easy and simple to clean.
- Wholly conforms to CE directives.
- Very easy and simple to use.

AUTOMATIC CLIPS MACHINE

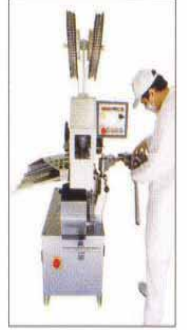
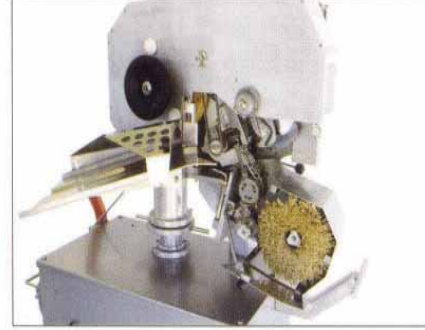

Capacity Kg/H	3600						
Engine Power Kw	1,5						
Net Weight Kg	400						
Dimensions (mm)	A	B	C	D	E	F	G
	1310	1035	1953	847	1882	1353	×

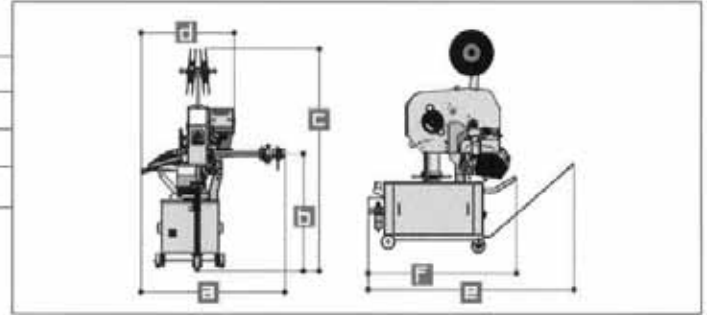

Technical Specification

The machine is capable of completing up to 85 clips with 65 calibres per minute. All automatic filling machines could be easily and rapidly calibrated by using two setting points. Yarn tying unit could be added optionally.

- Made up of aluminium and 304 quality stainless steel.
- With safety switch.
- Equipped with a pins unit and operates in frequency with the filling signal.
- Semi-automatic or full-automatic operation.
- Very easy and simple to use as to the operator panel.
- Entirely made up of 304 quality stainless metal.
- Hygienic
- Extremely easy and simple to clean.
- Wholly conforms to CE directives.
- Very easy and simple to use.

CUTTER 100 LITRES



Capacity Kg/H	480						
Engine Power Kw	17-20						
Net Weight Kg	1250						
Dimensions (mm)	A	B	C	D	E	F	G
	1844	1167	1630	1363	908	×	×

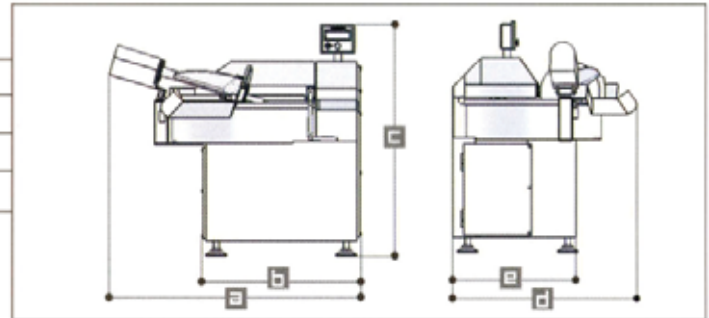

Technical Specification

Vessels and frames of all models are made up of 304 quality stainless chromium. They could be equipped with double-revolution or speed control apparatus (with frequency convertor) as desired. Models with frequency convertor are capable of emission and to increase/decrease the engine rate. 4 or 8 European blades are used. Ctr-200 and ctr-300 could be equipped with optional loading apparatus. The loading and unloading system is hydraulic. The operator panel is equipped with a graphic display and 25 programs. Internal and external temperatures could be monitored from the display. Hygienic. Easy to maintain and mount.

- Entirely made up of 304 quality stainless metal,
- Hygienic.
- Extremely easy and simple to clean.
- Wholly conforms to CE directives.
- Very easy and simple to use.

AUTOMATIC FILLING MACHINE



Capacity Kg/H	2000-3500							
Engine Power Kw	8.3 kW - 8.5 Ab							
Net Weight Kg	1100							
Bowl Capacity	200 Lt.							
Vacuum Pump	2mbar-25m3 Shell Vitrea 100 Vacuum Oil							
Dimensions (mm)	A	B	C	D	E	F	G	H
	2705	1883	1080	1155	2001	1566	1028	1389

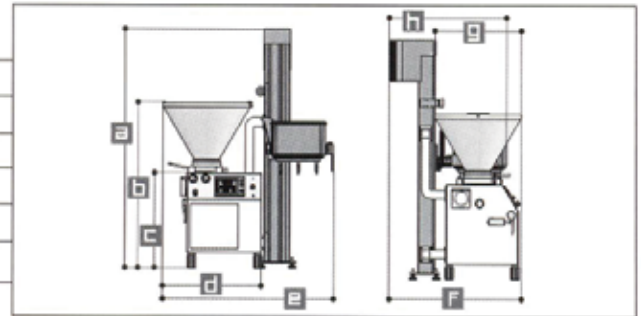

Technical Specification

Used in sausage, spiced sausage and salami production. Capable of filling at the desired weight and automatically. Equipped with a pallet system comprising of 6 pallets. Thanks to the European vacuum system, prevents air to be trapped within the package and ensures complete filling.

- Capable of operating serially with automatic clips tanks to the communication link .
- With lift
- Produces sausage portions rapidly tanks to the sausage apparatus.
- Capacity of 250 lt. of meat. - With safety switch.
- Entirely made up of 304 quality stainless metal
- Hygienic.
- Extremely easy and simple to clean.
- Wholly conforms to CE directives.
- Very easy and simple to use.

COOKING DRYING SMOKING OVEN

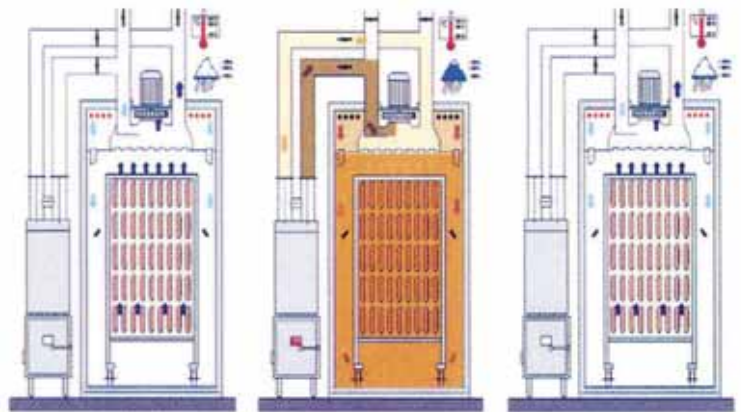

Capacity Kg/H	150						
Engine Power Kw	1,5 - 2,5 kW						
Net Weight Kg	800						
Dimensions (mm)	A	B	C	D	E	F	G
	2305	1165	839	1151	×	×	×

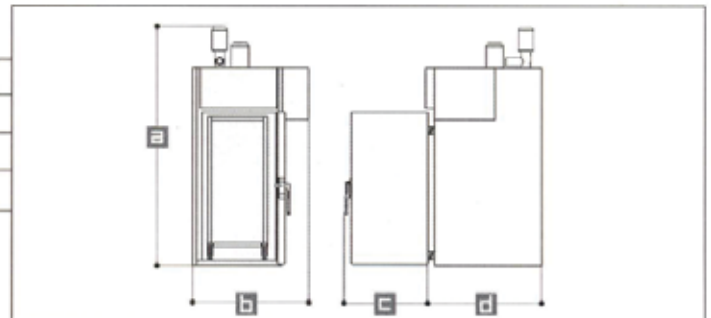

Technical Specification

Used in sa usage, spiced sausage and salami production and to smoke fish. Capable of cooking, boiling, frying and smoking. The heating system could be steam, electric, with boiler (natural gas or diesel fuel as desired). Easy to use and program tanks to the full-automatic electronic board. Equipped with a thermometer to automatically read and transmit the wet, dry and humid temperatures. Comes with a printer outlet for quality control purposes. Air-condition system could be added optionally. Models with 1, 2 and 4 trolleys are standard and special ovens could be manufactured on demand.

- Entirely made up of 304 quality stainless metal.
- Hygienic.
- Extremely easy and simple to clean.
- Wholly conforms to CE directives.
- Very easy and simple to use.



OSTIM INDUSTRIAL INVESTMENT & BUSINESS INC.

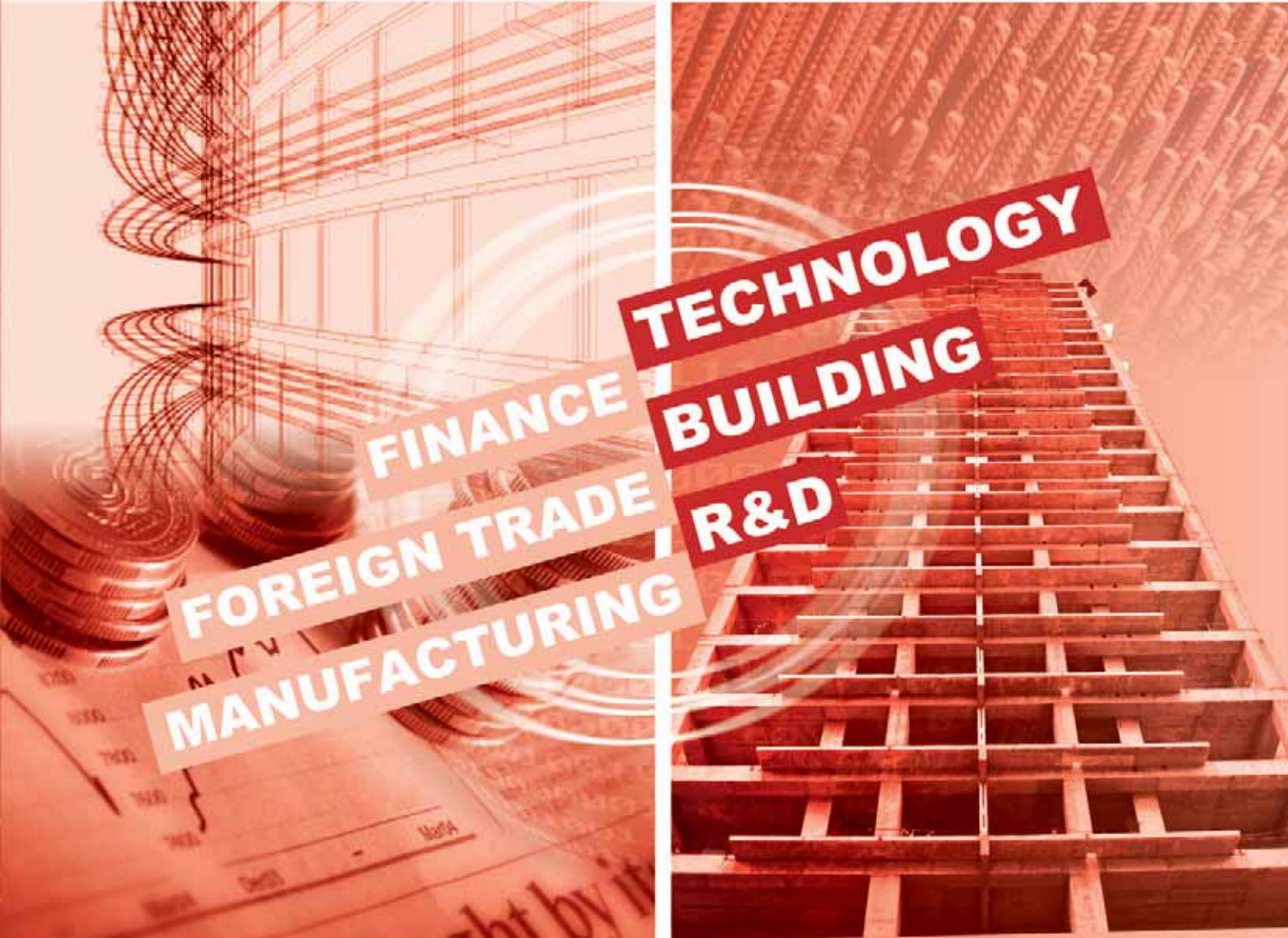

www.ostimyatirim.com.tr

www.ostimyatirim.com.tr



OSTİM INDUSTRIAL INVESTMENT & BUSINESS INC.

Address : 100. Yıl Bulvarı No: 101/A,

06370, Ostim-ANKARA

Phone : +90 312 385 34 09

Fax : +90 312 385 24 19

E-Mail : info@ostimyatirim.com.tr